



FSEZ2016 — Low-Power Green-Mode EZSWITCH™ without Secondary Side Feedback Circuitry

Features

- Linearly Decreasing PWM Frequency
- Green Mode Under Light-load and Zero-Load Conditions
- Constant Voltage (CV) and Constant Current (CC) around $\pm 25\%$ without Secondary Side Feedback Circuitry
- Precise Constant Voltage (CV) at $\pm 5\%$ by Secondary Side Feedback Circuitry
- Low Startup Current: $8\mu\text{A}$
- Low Operating Current: 3.6mA
- Leading-Edge Blanking (LEB)
- Constant Power Limit
- Universal AC Input Range
- Synchronized Slope Compensation
- 140°C OTP Sensor with Hysteresis
- V_{DD} Over-Voltage Clamping
- Cycle-by-Cycle Current Limiting
- Under-Voltage Lockout (UVLO)
- Fixed PWM Frequency with Hopping
- Gate Output Maximum Voltage Clamped at 17V

Applications

General-purpose switching-mode power supplies and flyback power converters, such as:

- Battery Chargers for Cellular Phones, Cordless Phones, PDAs, Digital Cameras, Power Tools
- Power Adapters for Ink Jet Printers, Video Game Consoles, Portable Audio Players
- Open-Frame SMPS for TV/DVD Standby and Auxiliary Supplies, Home Appliances, Consumer Electronics
- Replacement for Linear Transformers and RCC SMPS
- PC 5V Standby Power

Related Resources

- [AN-6081 — Low-Power Green-Mode EZSWITCH™ without Secondary Feedback](#)

Description

This highly integrated PWM controller provides several features to enhance the performance of low-power flyback converters. To minimize standby power consumption, a proprietary green-mode function provides off-time modulation to linearly decrease the switching frequency under light-load and zero-load conditions. This green mode enables the power supply to meet international power conservation requirements. The supply voltage V_{DD} is also used for feedback compensation, to regulate the output voltage without requiring a conventional TL431 and a photo-coupler. A typical output CV/CC characteristic is shown in Figure 1.

Another advantage of the FSEZ2016 is that the typical startup current is only $8\mu\text{A}$, while the typical operating current can be as low as 3.6mA . A large startup resistance can be used to achieve even higher power conversion efficiency.

FSEZ2016 integrates frequency hopping function internally to reduce EMI emissions with minimum line filters. Also, built-in synchronized slope compensation maintains the stability of peak current-mode control. Proprietary internal compensation ensures constant output power limiting over a universal range of AC input voltages, from $90V_{\text{AC}}$ to $264V_{\text{AC}}$.

The FSEZ2016 provides many protection functions. Pulse-by-pulse current limiting ensures constant output current, even if a short circuit occurs. The internal protection circuit disables PWM output if V_{DD} exceeds 22.7V . The gate output is clamped at 17V to protect the power MOS from over-voltage damage. The built-in over-temperature protection (OTP) function shuts down the controller at 140°C with a 30°C hysteresis.

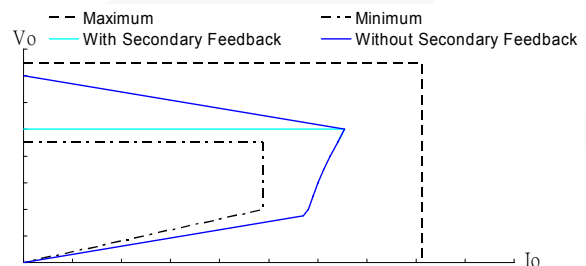



Figure 1. Typical Output V-I Characteristic

Ordering Information

Part Number	Operating Temperature Range	 Eco Status	Package	Packing Method
FSEZ2016NY	-40°C to +105°C	Green	7-Lead, Dual Outline Package (DIP-7)	Tube

 For Fairchild's definition of Eco Status, please visit: http://www.fairchildsemi.com/company/green/rohs_green.html.

Application Diagram

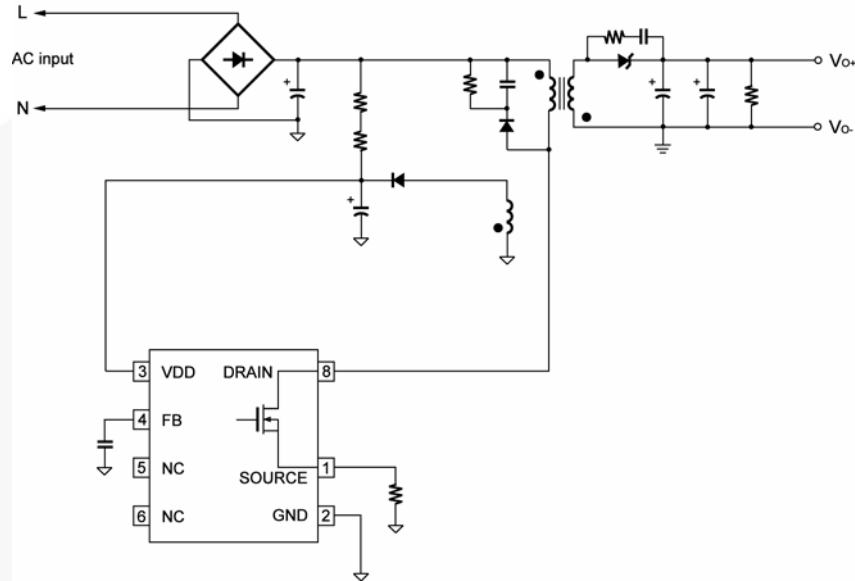

Figure 2. Typical Application

Internal Block Diagram

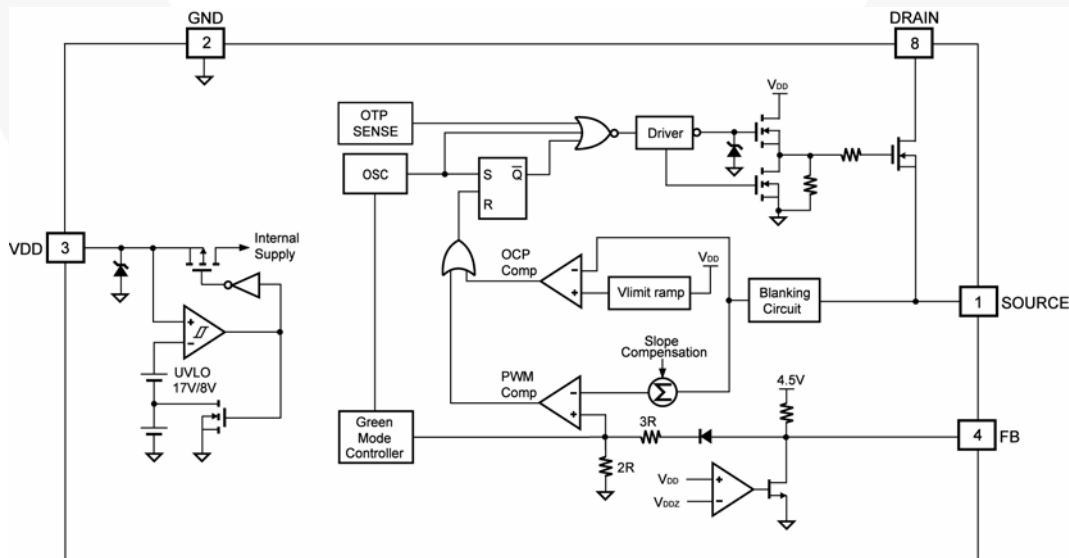
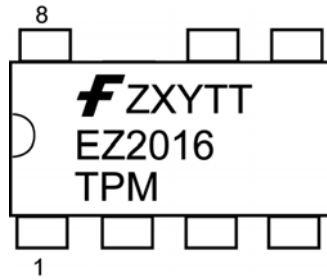

Figure 3. Functional Block Diagram

Marking Information



1st line
 Z: Assembly plant code
 X: Year code
 Y: Week code
 TT: Die run code
 3rd line
 T: Package type (N=DIP)
 P: Y=Green package
 M: Manufacture flow code

Figure 4. Top Mark

Pin Configuration

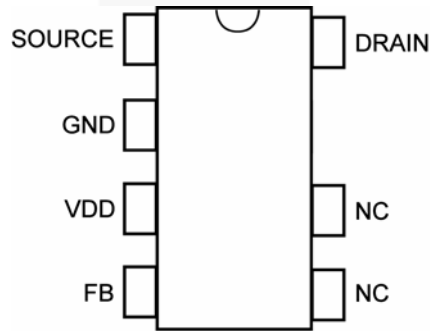

Figure 5. Pin Assignments

Pin Definitions

Pin #	Name	Description
1	SOURCE	Power MOSFET source. This is the high-voltage power MOSFET source.
2	GND	Ground
3	VDD	Power supply
4	FB	The FB pin provides feedback information to the internal PWM comparator. This feedback is used to control the duty cycle. When no feedback is provided, this pin is left open.
5	NC	No connection
6	NC	No connection
8	DRAIN	Power MOSFET drain. This is the high-voltage power MOSFET drain.

Absolute Maximum Ratings

Stresses exceeding the absolute maximum ratings may damage the device. The device may not function or be operable above the recommended operating conditions and stressing the parts to these levels is not recommended. In addition, extended exposure to stresses above the recommended operating conditions may affect device reliability. The absolute maximum ratings are stress ratings only.

Symbol	Parameter		Min.	Max.	Unit
V _{DD}	DC Supply Voltage ^(1, 2)			30	V
V _{FB}	Input Voltage to FB Pin		-0.3	7.0	V
V _{SENSE}	Input Voltage to Sense Pin		-0.3	7.0	V
P _D	Power Dissipation (T _A =25°C)			1.2	W
θ _{JA}	Thermal Resistance (Junction to Air)			98.7	°C/W
T _J	Operating Junction Temperature		-40	150	°C
T _{STG}	Storage Temperature Range		-55	150	°C
T _L	Lead Temperature (Wave Soldering or IR, 10 Seconds)			260	°C
ESD	Electrostatic Discharge Capability	Human Body Model (JEDEC:JESD22_A114)		2	KV
		Charged Device Model (JEDEC:JESD22_C101)		1	KV

Notes:

1. All voltage values, except differential voltages, are given with respect to GND pin.
2. Stresses beyond those listed under Absolute Maximum Ratings may cause permanent damage to the device.

Electrical Characteristics

Unless otherwise noted, $V_{DD}=15V$ and $T_A=25^\circ C$.

Symbol	Parameter	Conditions	Min.	Typ.	Max.	Units
V_{DD} Section						
V _{DD-OP}	Continuously Operation Voltage	With Secondary Feedback			20.0	V
		Without Secondary Feedback			22.7	
V _{DD-ON}	Turn-on Threshold Voltage		16	17	18	V
V _{DD-OFF}	Turn-off Threshold Voltage		7.5	8.0	8.5	V
I _{DD-ST}	Startup Current	$V_{DD}=V_{DD-ON} - 0.1V$		8	20	μA
I _{DD-OP}	Operating Supply Current	$C_L=1nF$		3.6	4.6	mA
V _{DD-G-OFF}	V _{DD} Low-threshold Voltage to Exit Green-off Mode			V _{DD-OFF} +1.3		V
Feedback Input Section						
A _V	Input-Voltage to Current-Sense Attenuation			0.35		V/V
Z _{FB}	Input Impedance	$I_{FB}=0.1mA$ to $0.2mA$		4.6		kΩ
V _{FB-OPEN}	Open-Loop Voltage		4.5			V
V _{DD-FB}	V _{DD} Feedback Threshold Voltage	FB is Open	20.7	22.7	24.7	V
		$I_{FB}=0.4mA$	18.4	20.4	22.4	V
Current-Sense Section						
t _{PD}	Propagation Delay			100	150	ns
V _{STHVA}	Current Limit Valley Threshold Voltage	V _{DD} =18V		0.83		V
		V _{DD} =15V		0.74		V
		V _{DD} =10V		0.59		V
V _{STHFL}	Current Limit Flat Threshold Voltage	V _{DD} =18V		1.15		V
		V _{DD} =15V		1.04		V
		V _{DD} =10V		0.84		V
t _{LEB}	Leading-Edge Blanking Time		220	310	400	ns

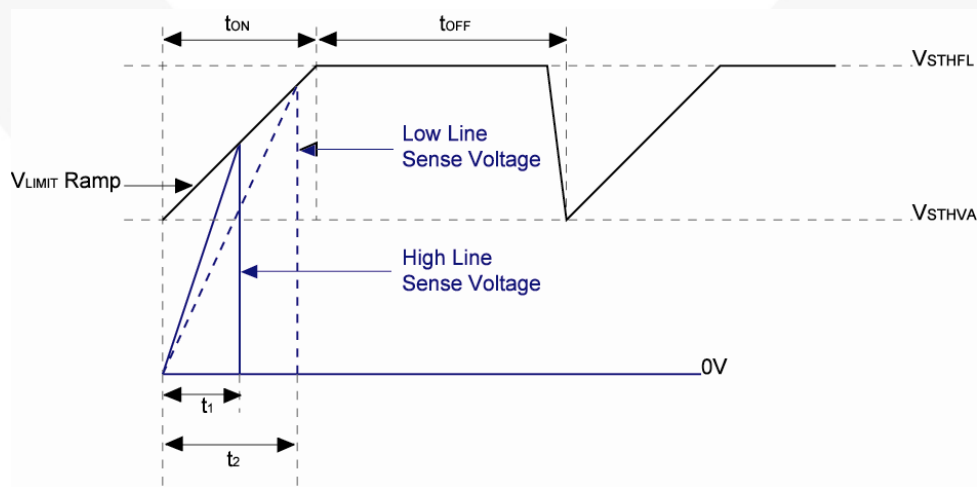

Figure 6. Saw Limit

Electrical Characteristics (Continued)

Unless otherwise noted, $V_{DD}=15V$ and $T_A=25^{\circ}C$.

Symbol	Parameter	Conditions	Min.	Typ.	Max.	Units
Oscillator Section						
f_{OSC}	Frequency	Center Frequency	60	65	70	kHz
		Hopping Range	± 4.1	± 4.7	± 5.3	
t_{HOP}	Hopping Period			4		ms
f_{OSC-G}	Green Mode Frequency		14.5	17.0	19.5	KHz
V_{FB-N}	Green Mode Entry FB Voltage		2.3	2.6	2.9	V
V_{FB-G}	Green Mode Ending FB Voltage			$V_{FB-N} - 0.75$		V
V_{FB-Z}	Zero Duty Cycle FB Voltage			1.4		V
S_G	Green Mode Modulation Slope		40	70	100	Hz/mV
f_{DV}	Frequency Variation vs. V_{DD} Deviation	$V_{DD}=10$ to $22V$			5	%
f_{DT}	Frequency Variation vs. Temperature Deviation	$T_A = -20$ to $85^{\circ}C$		1.5	5.0	%
Internal MOSFET Section						
DCY_{MAX}	Maximum Duty Cycle		69	74	79	%
BV_{DSS}	Drain-Source Breakdown Voltage		$I_D=250\mu A, V_{GS}=0V$	600		V
$\Delta BV_{DSS}/\Delta T_J$	Breakdown Voltage Temperature Coefficient		$I_D=250\mu A,$ Referenced to $25^{\circ}C$	0.6		$V/^{\circ}C$
I_S	Maximum Continuous Drain-Source Diode Forward Current				1	A
I_{SM}	Maximum Pulsed Drain-Source Diode Forward Current				4	A
$R_{DS(ON)}$	Static Drain-Source On-Resistance		$I_D=0.5A, V_{GS}=10V$	9.3	11.5	Ω
I_{DSS}	Drain-Source Leakage Current		$V_{DS}=600V, V_{GS}=0V,$ $T_C=25^{\circ}C$		5	μA
			$V_{DS}=480V, V_{GS}=0V,$ $T_C=100^{\circ}C$		10	μA
t_{D-ON}	Turn-on Delay Time		$V_{DS}=300V, I_D=1.1A,$ $R_G=25\Omega$	7	24	ns
t_r	Rise Time			21	52	ns
t_{D-OFF}	Turn-off Delay Time			13	36	ns
t_f	Fall Time			27	64	ns
C_{ISS}	Input Capacitance		$V_{GS}=0V, V_{DS}=25V,$ $f_s=1MHz$	130	170	pF
C_{OSS}	Output Capacitance			19	25	pF
Over Temperature Protection (OTP)						
T_{OTP}	Protection Junction Temperature			140		$^{\circ}C$
$T_{OTP-RESTART}$	Restart Junction Temperature			110		$^{\circ}C$

Typical Performance Characteristics

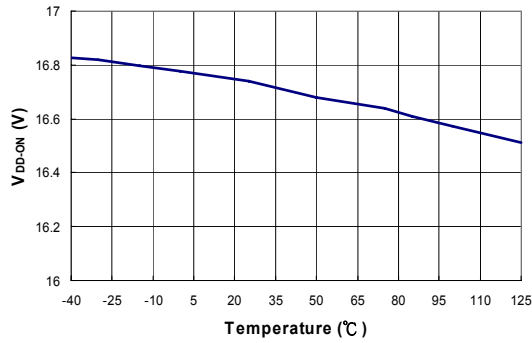

Figure 7. Turn-on Threshold Voltage (V_{DD-ON}) vs. Temperature

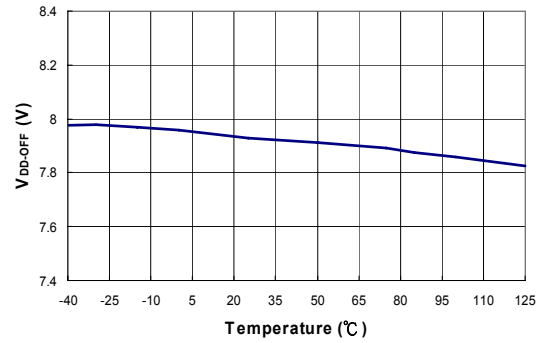

Figure 8. Turn-off Threshold Voltage (V_{DD-OFF}) vs. Temperature

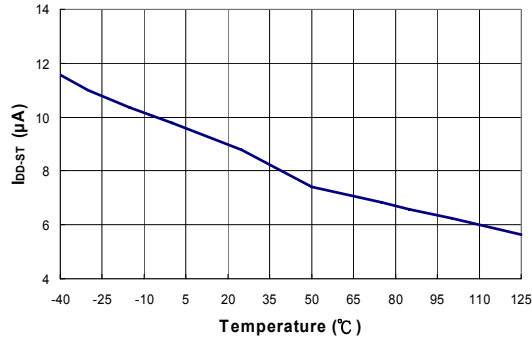

Figure 9. Startup Current (I_{DD-ST}) vs. Temperature

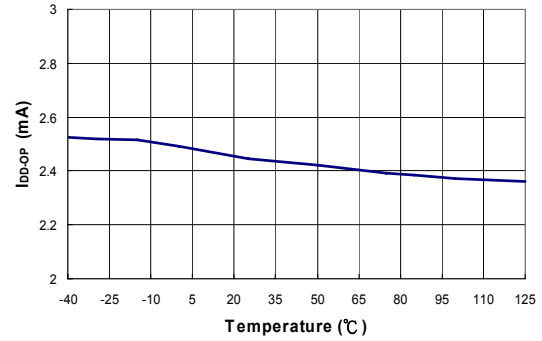

Figure 10. Operating Supply Current (I_{DD-OP}) vs. Temperature

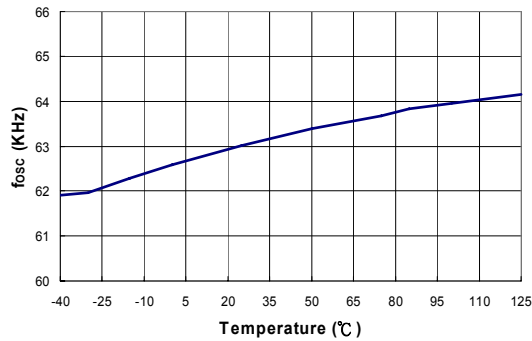

Figure 11. Center Frequency (f_{OSC}) vs. Temperature

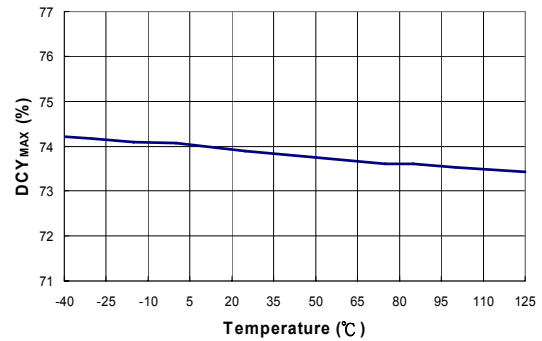

Figure 12. Maximum Duty Cycle (DCY_{MAX}) vs. Temperature

Typical Performance Characteristics (Continued)

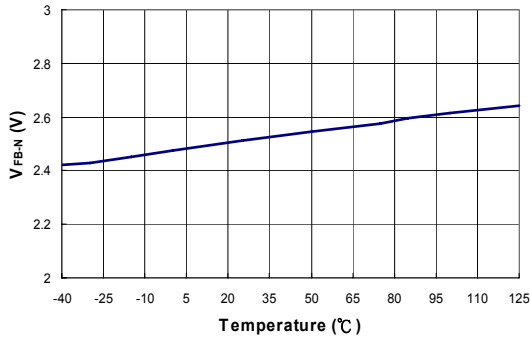

Figure 13. Green-Mode Entry FB Voltage (V_{FB-N}) vs. Temperature

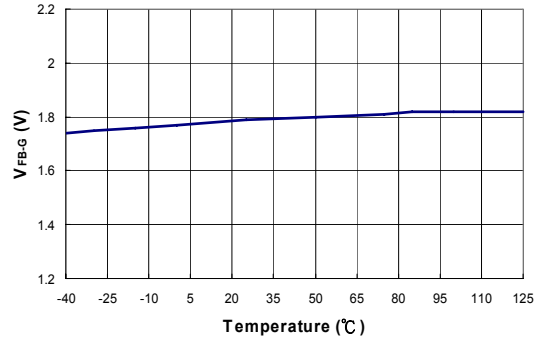

Figure 14. Green-Mode Ending FB Voltage (V_{FB-G}) vs. Temperature

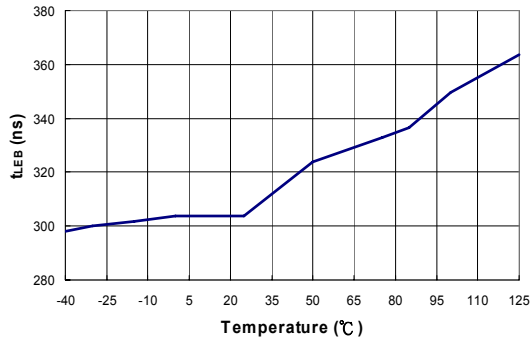

Figure 15. Leading-Edge Blanking Time (t_{LEB}) vs. Temperature

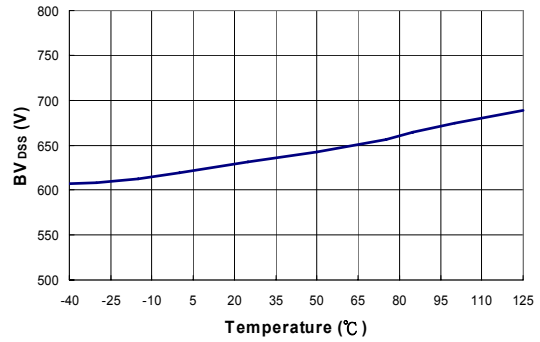

Figure 16. Drain-Source Breakdown Voltage (BV_{DSS}) vs. Temperature



Operation Description

FSEZ2016 devices integrate functions for low-power switch-mode power supplies. The following descriptions highlight the key features of the FSEZ2016.

Startup Current

The required startup current is only 8 μ A. This allows a high-resistance, low-wattage startup resistor to supply the controller's startup power. A 1.5M Ω /0.25W startup resistor can be used over a wide input range (100V-240V_{AC}) with very little power loss.

Operating Current

The operating current is normally 3.6mA, which results in higher efficiency and reduces the required V_{DD} hold-up capacitance. A 10 μ F/25V V_{DD} hold-up capacitor can be used over a wide input range (90V-264V_{AC}) with very little power loss.

Green-Mode Operation

The proprietary green-mode function provides off-time modulation to linearly decrease the switching frequency under light-load and zero-load conditions. The on-time is limited to provide better protection against brownouts and other abnormal conditions. Power supplies using the FSEZ2016 can meet international restrictions regarding standby power-consumption.

Constant Voltage (CV) and Constant Current (CC) without Feedback

The FSEZ2016 can tightly regulate the output voltage and provide over-current protection without requiring secondary-side feedback signals. For improved CV and CC accuracy, the transformer leakage inductance should be reduced as much as possible.

Over-Temperature Protection (OTP)

The FSEZ2016 has a built-in temperature-sensing circuit to shut down PWM output if the junction temperature exceeds 140°C. While PWM output is shut down, the V_{DD} voltage gradually drops to the UVLO voltage. Some of the internal circuits are shut down, and V_{DD} gradually starts increasing again. When V_{DD} reaches 17V, all the internal circuits, including the temperature-sensing circuit, operate normally. If the junction temperature is still higher than 140°C, the PWM controller shuts down immediately. This situation continues until the temperature drops below 110°C. The PWM output is then turned back on. The temperature hysteresis window for the OTP circuit is 30°C.

V_{DD} Over-Voltage Clamping

V_{DD} over-voltage clamping is built in to prevent damage from over-voltage conditions. When V_{DD} exceeds 22.7V, PWM output is shut down. Over-voltage conditions may be caused by an open photo-coupler loop or a short circuit in the output.

Oscillator Operation

The oscillation frequency is fixed at 65KHz.

Leading-Edge Blanking (LEB)

Each time the power MOSFET is switched on, a turn-on spike occurs at the sense-resistor. To avoid premature termination of the switching pulse, a 310ns leading-edge blanking time is built in. Conventional RC filtering is not necessary. During this blanking period, the current-limit comparator is disabled and cannot switch off the gate drive.

Constant Output Power Limit

When the SENSE voltage across the sense resistor R_S reaches the threshold voltage, the output GATE drive is turned off following a small propagation delay, t_{PD}. This propagation delay introduces an additional current proportional to t_{PD}•V_{IN}/L_P. The propagation delay is nearly constant, regardless of the input line voltage V_{IN}. Higher input line voltages result in larger additional currents. Under high input-line voltages, the output power limit is higher than under low input-line voltages. Over a wide range of AC input voltages, the variation can be significant. To compensate for this, the threshold voltage is adjusted by adding a positive ramp (V_{limit_ramp}). This ramp signal can vary from 0.74V to 1.04V and flattens out at 1.04V. A smaller threshold voltage forces the output GATE drive to terminate earlier, reducing total PWM turn-on time and making the output power equal to that of the low line input. This proprietary internal compensation feature ensures a constant output power limit over a wide range of AC input voltages (90V-264V_{AC}).

Under Voltage Lockout (UVLO)

The turn-on/turn-off thresholds are fixed internally at 17V and 8V. To enable the FSEZ2016 during startup, the hold-up capacitor must first be charged to 17V through the startup resistor. The hold-up capacitor continues to supply V_{DD} before energy can be delivered from the auxiliary winding of the main transformer. V_{DD} must not drop below 8V during this startup process. This UVLO hysteresis window ensures that the hold-up capacitor can adequately supply V_{DD} during startup.

Gate Output

The BiCMOS output stage is a fast totem-pole gate driver. Cross-conduction is avoided to minimize heat dissipation, increase efficiency, and enhance reliability. The output driver is clamped by an internal 17V Zener diode to protect the power MOSFET transistors against any harmful over-voltage gate signals.

Operation Description (Continued)

Slope Compensation

The sensed voltage across the current sense resistor is used for current mode control and pulse-by-pulse current limiting. The built-in slope compensation improves power supply stability. Furthermore, it prevents sub-harmonic oscillations that normally would occur because of peak current mode control. A positively sloped, synchronized ramp is activated with every switching cycle. The slope of the ramp is:

$$\frac{0.33 \times \text{Duty}}{\text{Duty}(\text{max.})} \quad (1)$$

Noise Immunity

Noise from the current sense or the control signal may cause significant pulse-width jitter, particularly in continuous-conduction mode. Slope compensation helps alleviate this problem. Good placement and layout practices should be followed. The designer should avoid long PCB traces and component leads. Compensation and filter components should be located near the FSEZ2016. Finally, increasing the power-MOS gate resistance is advised.

Applications Information

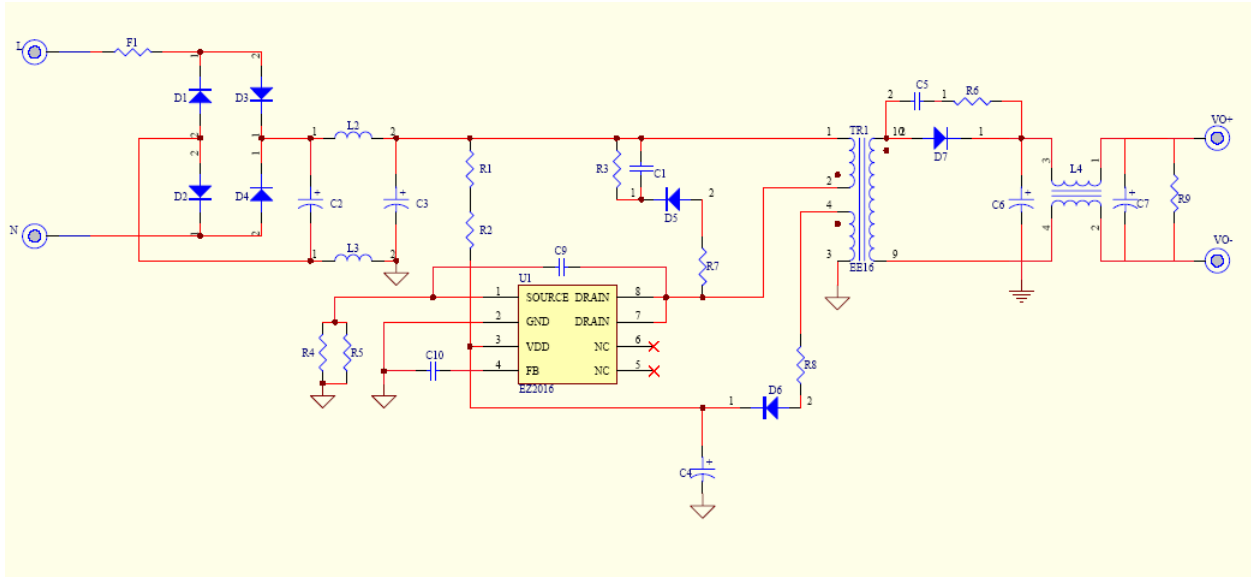

Figure 17. Reference Circuit (without Secondary-Side Feedback)

BOM

Reference	Component	Reference	Component
C1	CC 4.7nF/1kV	F1	R 1Ω/1W
C2	EC 4.7μF/400V 105°C	L2	Inductor 4.7μH
C3	EC 4.7μF/400V 105°C	L3	Inductor 470μH
C4	EC 10μF/50V 105°C	L4	Inductor 80μH
C5	CC 1nF/1kV	R1	R 750kΩ
C6	EC 560μF/10V	R2	R 750kΩ
C7	EC 560μF/10V	R3	R 100kΩ
C9	Open	R4	R 10Ω
C10	CC 1nF	R5	R 2.2Ω
D1	Diode 1N4007	R6	R 47Ω
D2	Diode 1N4007	R7	R 270Ω
D3	Diode 1N4007	R8	R 0Ω
D4	Diode 1N4007	R9	R 2kΩ
D5	Diode FR107	T1	Transformer EE-16
D6	Diode FR102	U1	IC FSEZ2016
D7	Diode SB560		

Applications Information (Continued)

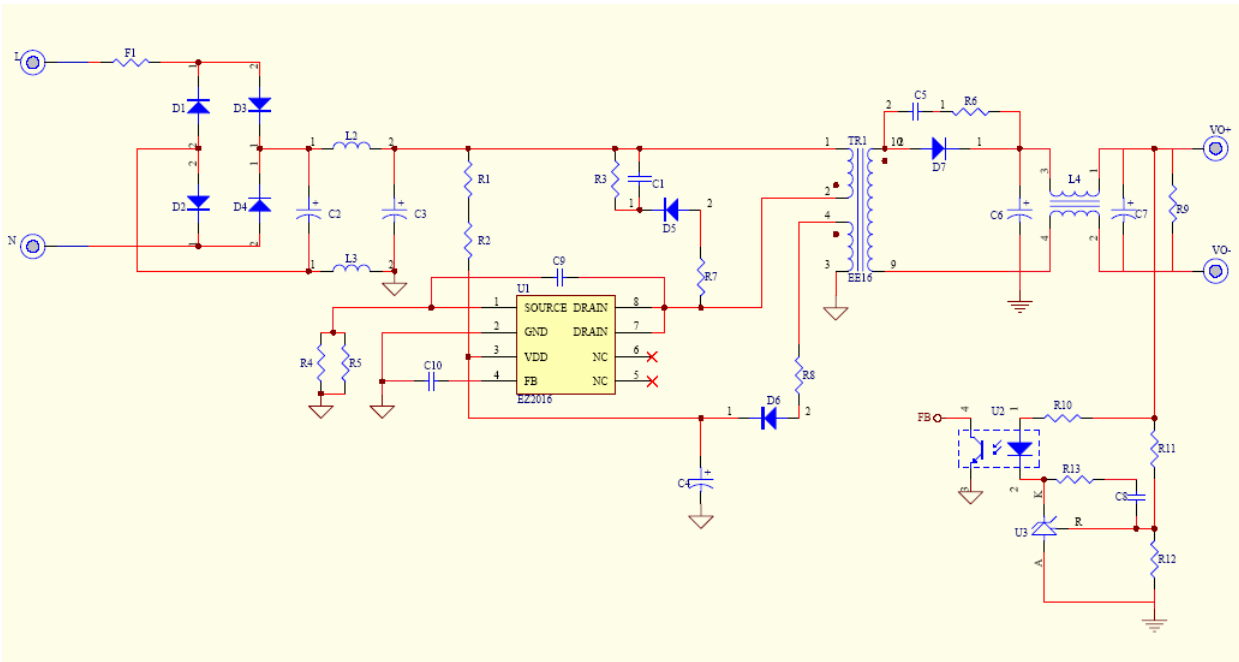
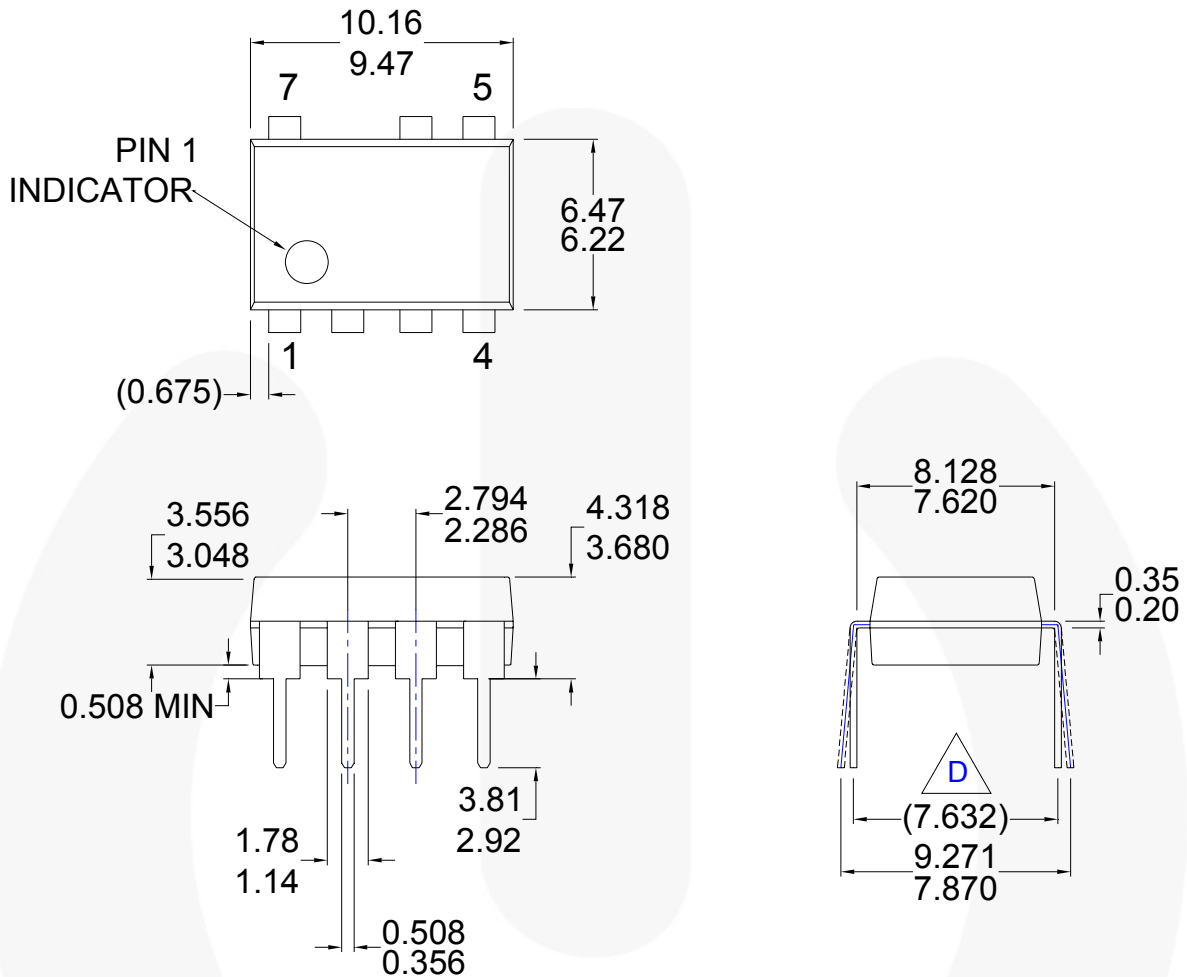

Figure 18. Reference Circuit (with Secondary-Side Feedback)

BOM

Reference	Component	Reference	Component
C1	CC 4.7nF/1kV	L3	Inductor 470μH
C2	EC 4.7μF/400V 105°C	L4	Inductor 80μH
C3	EC 4.7μF/400V 105°C	R1	R 750kΩ
C4	EC 10μF/50V 105°C	R2	R 750kΩ
C5	CC 1nF/1kV	R3	R 100kΩ
C6	EC 560μF/10V	R4	R 10Ω
C7	EC 560μF/10V	R5	R 2.2Ω
C8	CC 2.2nF	R6	R 47Ω
C9	Open	R7	R 270Ω
C10	CC 1nF	R8	R 0Ω
D1	Diode 1N4007	R9	R 2kΩ
D2	Diode 1N4007	R10	R 560Ω
D3	Diode 1N4007	R11	R 20kΩ
D4	Diode 1N4007	R12	R 20kΩ
D5	Diode FR107	R13	R 20kΩ
D6	Diode FR102	T1	Transformer EE-16
D7	Diode SB560	U1	IC FSEZ2016
F1	R 1Ω/1W	U2	IC PC817
L2	Inductor 4.7μH	U3	IC TL431

Physical Dimensions



NOTES:

- A) THIS PACKAGE CONFORMS TO JEDEC MS-001 VARIATION AA EXCEPT LEAD COUNT.
- B) ALL DIMENSIONS ARE IN MILLIMETERS.
- C) DIMENSIONS ARE EXCLUSIVE OF BURRS, MOLD FLASH, AND TIE BAR EXTRUSIONS.
-  D) DIMENSION WITH TERMINALS CONSTRAINED PERPENDICULAR TO PRINTED CIRCUIT BOARD.
- E) DRAWING FILE NAME: MKT-N07CREV1

Figure 19. 7-Pin DIP-7 Package







Package drawings are provided as a service to customers considering Fairchild components. Drawings may change in any manner without notice. Please note the revision and/or date on the drawing and contact a Fairchild Semiconductor representative to verify or obtain the most recent revision. Package specifications do not expand the terms of Fairchild's worldwide terms and conditions, specifically the warranty therein, which covers Fairchild products.

Always visit Fairchild Semiconductor's online packaging area for the most recent package drawings:
<http://www.fairchildsemi.com/packaging/>.



TRADEMARKS

The following includes registered and unregistered trademarks and service marks, owned by Fairchild Semiconductor and/or its global subsidiaries, and is not intended to be an exhaustive list of all such trademarks.

- | | | | |
|---|---|---|---|
| Auto-SPM™ | F-PFST™ | PowerTrench® | The Power Franchise® |
| Build it Now™ | FRFET® | PowerXS™ |  |
| CorePLUS™ | Global Power Resource SM | Programmable Active Droop™ | TinyBoost™ |
| CorePOWER™ | Green FPS™ | QFET® | TinyBuck™ |
| CROSSVOLT™ | Green FPS™ e-Series™ | QS™ | TinyLogic® |
| CTL™ | Gmax™ | Quiet Series™ | TINYOPTO™ |
| Current Transfer Logic™ | GTO™ | RapidConfigure™ | TinyPower™ |
| EcoSPARK® | IntelliMAX™ |  | TinyPWM™ |
| EfficientMax™ | ISOPLANAR™ | Saving our world, 1mW/W/KW at a time™ | TinyWire™ |
| EZSWITCH™ | MegaBuck™ | SmartMax™ | TriFault Detect™ |
|  | MICROCOUPLER™ | SMART START™ | TRUECURRENT™ |
|  | MicroFET™ | SPM® | µSerDes™ |
| Fairchild® | MicroPak™ | STEALTH™ |  |
| Fairchild Semiconductor® | MillerDrive™ | SuperFET™ | UHC® |
| FACT Quiet Series™ | MotionMax™ | SuperSOT™-3 | Ultra FRFET™ |
| FACT® | Motion-SPM™ | SuperSOT™-6 | UniFET™ |
| FAST® | OPTOLOGIC® | SuperSOT™-8 | Vcx™ |
| FastvCore™ | OPTOPLANAR® | SupreMOS™ | VisualMax™ |
| FETBench™ |  | SyncFET™ | XST™ |
| FlashWriter® | PDP SPM™ | Sync-Lock™ | |
| FPS™ | Power-SPM™ |  | |

* Trademarks of System General Corporation, used under license by Fairchild Semiconductor.

DISCLAIMER

FAIRCHILD SEMICONDUCTOR RESERVES THE RIGHT TO MAKE CHANGES WITHOUT FURTHER NOTICE TO ANY PRODUCTS HEREIN TO IMPROVE RELIABILITY, FUNCTION, OR DESIGN. FAIRCHILD DOES NOT ASSUME ANY LIABILITY ARISING OUT OF THE APPLICATION OR USE OF ANY PRODUCT OR CIRCUIT DESCRIBED HEREIN, NEITHER DOES IT CONVEY ANY LICENSE UNDER ITS PATENT RIGHTS, NOR THE RIGHTS OF OTHERS. THESE SPECIFICATIONS DO NOT EXPAND THE TERMS OF FAIRCHILD'S WORLDWIDE TERMS AND CONDITIONS, SPECIFICALLY THE WARRANTY THEREIN, WHICH COVERS THESE PRODUCTS.

LIFE SUPPORT POLICY

FAIRCHILD'S PRODUCTS ARE NOT AUTHORIZED FOR USE AS CRITICAL COMPONENTS IN LIFE SUPPORT DEVICES OR SYSTEMS WITHOUT THE EXPRESS WRITTEN APPROVAL OF FAIRCHILD SEMICONDUCTOR CORPORATION.

As used herein:

- Life support devices or systems are devices or systems which, (a) are intended for surgical implant into the body or (b) support or sustain life, and (c) whose failure to perform when properly used in accordance with instructions for use provided in the labeling, can be reasonably expected to result in a significant injury of the user.
- A critical component in any component of a life support, device, or system whose failure to perform can be reasonably expected to cause the failure of the life support device or system, or to affect its safety or effectiveness.

ANTI-COUNTERFEITING POLICY

Fairchild Semiconductor Corporation's Anti-Counterfeiting Policy. Fairchild's Anti-Counterfeiting Policy is also stated on our external website, www.fairchildsemi.com, under Sales Support.

Counterfeiting of semiconductor parts is a growing problem in the industry. All manufacturers of semiconductor products are experiencing counterfeiting of their parts. Customers who inadvertently purchase counterfeit parts experience many problems such as loss of brand reputation, substandard performance, failed applications, and increased cost of production and manufacturing delays. Fairchild is taking strong measures to protect ourselves and our customers from the proliferation of counterfeit parts. Fairchild strongly encourages customers to purchase Fairchild parts either directly from Fairchild or from Authorized Fairchild Distributors who are listed by country on our web page cited above. Products customers buy either from Fairchild directly or from Authorized Fairchild Distributors are genuine parts, have full traceability, meet Fairchild's quality standards for handling and storage and provide access to Fairchild's full range of up-to-date technical and product information. Fairchild and our Authorized Distributors will stand behind all warranties and will appropriately address any warranty issues that may arise. Fairchild will not provide any warranty coverage or other assistance for parts bought from Unauthorized Sources. Fairchild is committed to combat this global problem and encourage our customers to do their part in stopping this practice by buying direct or from authorized distributors.

PRODUCT STATUS DEFINITIONS

Definition of Terms

Datasheet Identification	Product Status	Definition
Advance Information	Formative / In Design	Datasheet contains the design specifications for product development. Specifications may change in any manner without notice.
Preliminary	First Production	Datasheet contains preliminary data; supplementary data will be published at a later date. Fairchild Semiconductor reserves the right to make changes at any time without notice to improve design.
No Identification Needed	Full Production	Datasheet contains final specifications. Fairchild Semiconductor reserves the right to make changes at any time without notice to improve the design.
Obsolete	Not In Production	Datasheet contains specifications on a product that is discontinued by Fairchild Semiconductor. The datasheet is for reference information only.

Rev. 140